

Wheel bearings must be OK.

Lift vehicle.

Check wheel for lateral runout with special tool 36 1 000 (measuring fixture), refer to Technical Data.

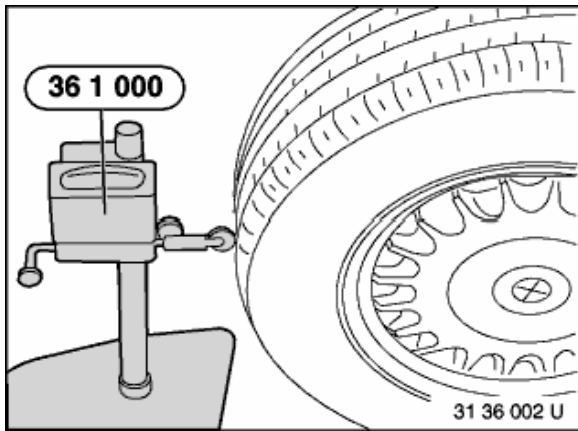

Check wheel for radial runout with special tool 36 1 000 (measuring fixture), refer to Technical Data.

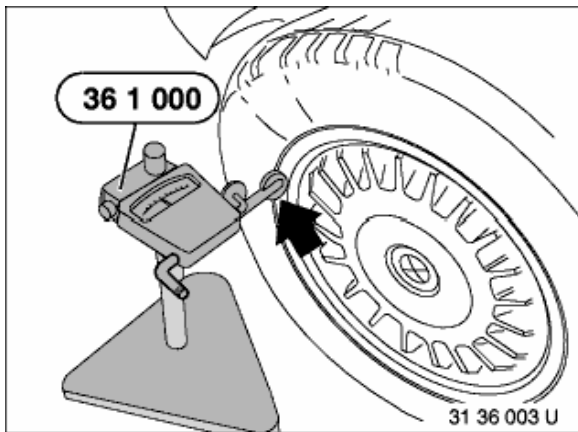

If applicable, remove balance weights.

Check lateral runout of rim with special tool 36 1 000 (measuring fixture), refer to Technical Data.

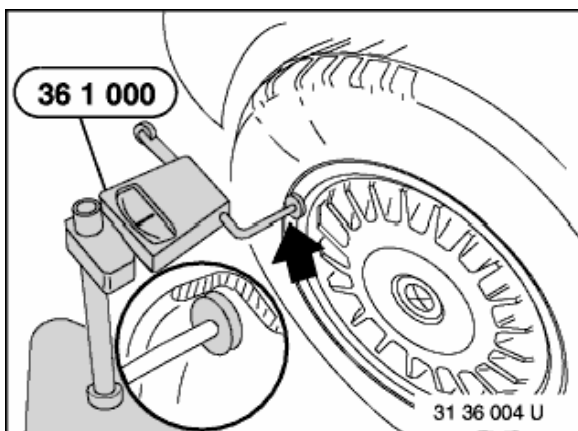

Check radial runout of rim with special tool 36 1 000 (measuring fixture), refer to Technical Data.